

# 0202 Dispensmove 200 Drawer

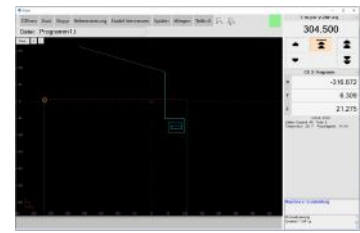

Image with Art. 3003 substructure and Art. 3103 Hood



0002 DiSoft



1701 Interface Card



1523 Needle sensor



2510 Purging unit

## Description

Automatic application of adhesives and sealants. Freely programmable for dosing dots, lines, arcs and combinations via PC.

Installation of various safety devices is possible, as is integration into an external control system.

Equipping via drawer system. Interchangeable equipping and removal possible.

An interface card switches various machine components via 12 inputs and outputs.

# 0202 Dispensmove 200 Drawer

Dimensional drawing (Dimensions in mm)

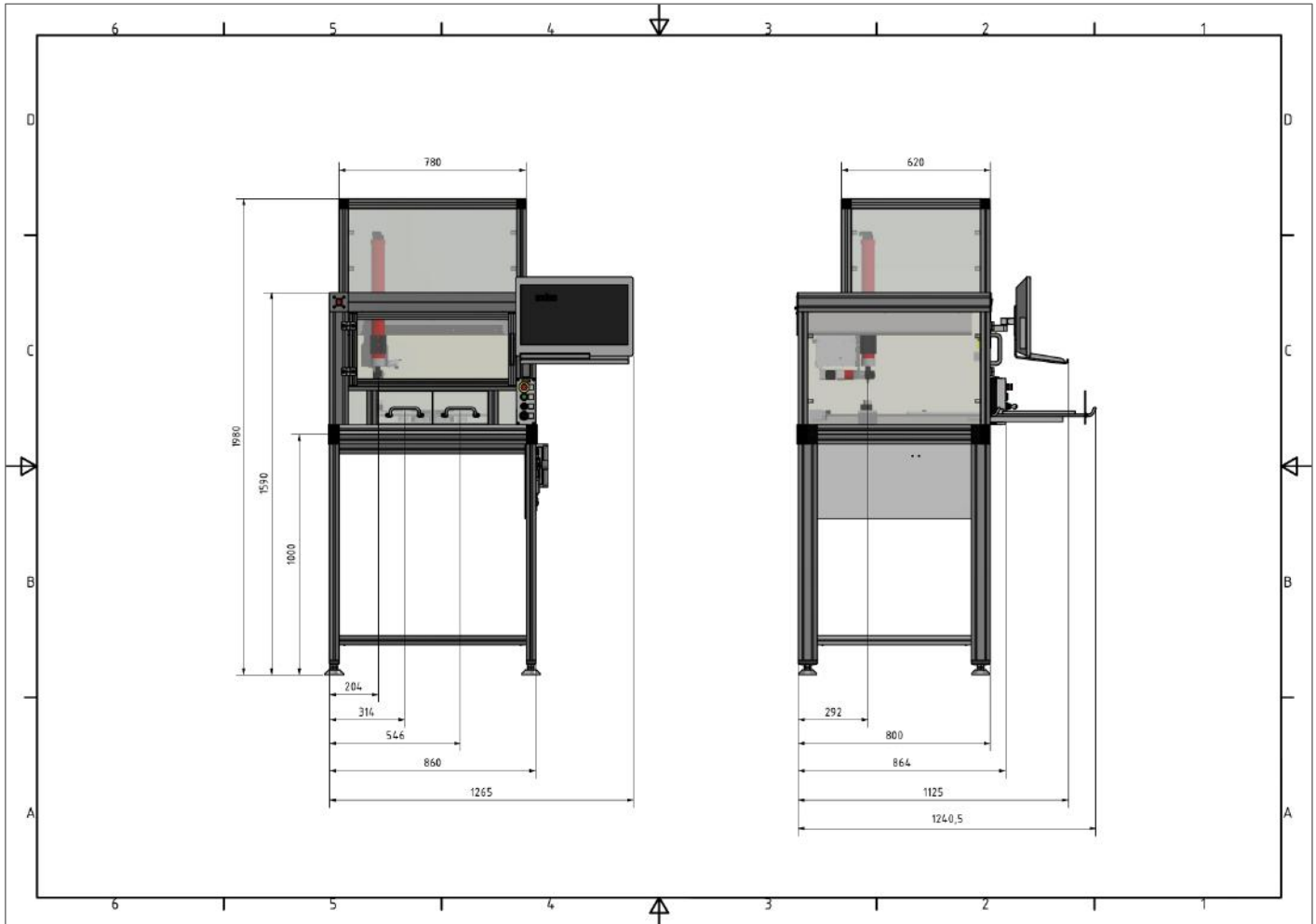

Interpolation	3D interpolation of the axes / control of the dosing valve via 4th axis
Positioning accuracy	X and Y = 0,1 mm / Z = 0,05 mm
Movement speed	Up to 400 mm/s
Possible axis workload	Up to 3 kg, optional to 7 kg
Programming	Software „DiSoft“ / Import of CAD files (hpgl.files)
Input / Output	12 Inputs, 12 Outputs
Working range	(x)480 (y)420 (z)100 mm
Dimensions	(W)860 (D)864 (H)1590 mm
Weight	Depending on equipment